



INSTALLATION MANUAL
#1000702MIA

LOCK-RIGHT BY POWERTRAX

AUTOMATIC POSITIVE-LOCKING DIFFERENTIAL

LOCK-RIGHT™ Performance Locker Installation Manual

Four-pinion differential; two-piece capped case

Typical of Suzuki Samurai (SJ-413), SJ-410, LJ-80, Sidekick, etc.

| | | | |
|--|----|---|----|
| Introduction | 2 | Assembly Inspection | 17 |
| Background Information | 3 | Third Member Installation | 18 |
| Installations Covered | 5 | Vehicle Final Assembly | 18 |
| Preliminary Steps | 5 | Tire Diameters | 18 |
| Removal and Disassembly | 5 | Testing the Complete Installation | 19 |
| Differential Case Removal | 6 | Driving Your Vehicle | 19 |
| Disassembly of Differential Case | 8 | Warranty Information | 20 |
| Inspection of the Parts | 8 | | |
| Preparing Parts for Assembly | 11 | | |
| Assembly of Parts into Case | 11 | | |
| Third Member Final Assembly | 16 | | |

The LOCK-RIGHT™ is manufactured in the U.S.A.

Powertrax by RICHMOND
1208 Old Norris Road, P.O. Box 238
Liberty, S.C. 29657

Introduction

Welcome to the growing family of **LOCK-RIGHT** owners! This manual will help you install your new **LOCK-RIGHT** automatic 100% full-locking differential. When the installation is complete, your vehicle will have *extreme* traction! We trust that you will be pleased with its performance and thank you for your confidence in our products.

LOCK-RIGHT installation simply involves disassembling and re-assembling the differential case, replacing a few parts in the process. These instructions are detailed to the point that a person who is reasonably familiar with automotive work can install a **LOCK-RIGHT** into a third member in about three to four hours; please read them carefully before you start to be sure that you thoroughly understand them. Do not attempt shortcuts unless you know exactly what you are doing. These instructions also assume that you have the proper shop manual for reference to instructions about axle removal,

torque values, settings, clearances, etc. that apply to your particular vehicle. Our manual is a general guide to operations but does not contain specific information for each vehicle.

We suggest that your **first installation be done in the rear axle**. The weight of the engine over the **front** axle is **reduced** by weight transfer to the rear as your vehicle climbs a hill, meaning that more and more weight is being applied to the **rear** axle, where the locker is located, as more **traction** is needed.

Remember: This instruction manual is provided for your convenience to assist you or your mechanic with the installation of your new **LOCK-RIGHT**. However, the ultimate responsibility for the success of your installation and the subsequent proper operation of your vehicle rest with you, the vehicle owner.

When your installation is complete, you will have a vehicle with significantly increased capabilities that will be hard to believe. For continued "fun in the sun," operate it in a safe and

responsible manner. *Be sure to read and understand the driving information* in the **LOCK-RIGHT** Vehicle Owner's Manual!

Background Information

The differential **case** is the round housing inside the rear axle assembly to which the ring gear is bolted and which contains the differential spider and side gear assembly. It is installed in the differential **carrier**, which is the housing that holds the case, drive pinion gear, bearings, etc. The carrier may be removable (as part of a "drop-out" unit, or third member), or it may be integral (as a permanent part of the axle assembly, mounted in the vehicle). This manual covers the removable third member, technically known as the Differential and Carrier Assembly.

The **LOCK-RIGHT** is designed to fit into **standard open differential cases only**, not into limited-slip (clutch-pack) type cases. If your vehicle contains a limited-slip unit you will need to purchase a standard open differential, thrust washers and

pinion shaft before proceeding.

A word about Pinion shafts: Some models of differential use shafts with circumferential oil grooves for oil distribution, while others use shafts with flats. The shafts with flats are re-used, while those with grooves are not. If new shafts are provided in your kit, use them. If no shafts are provided, use the existing shafts.

A word about side gear thrust washers: All differentials originally had a thrust washer under each side gear. Thrust washers are large in diameter and between about 1/32-inch (.031, or 0,76-mm) and 1/16-inch (.062, or 1,52-mm) thick. If either one or both are missing from the original differential, **obtain new one(s) before proceeding!** The **LOCK-RIGHT** is designed to be used with a correct thrust washer under **each** coupler, and failure to use this washer is easy to observe during inspection and will void the warranty.

NOTE: The parts shown in the various figures are typical and may not exactly depict your particular model.

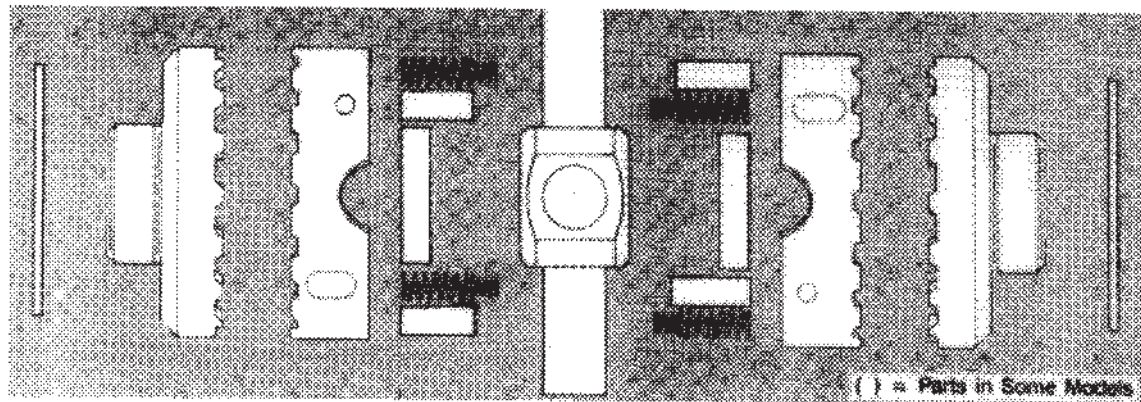

Thrust
Washer

Side
Gear

Driver

Stop
Pins;
Spacer

Pinion
Shaft(s)
(Block)

Bias
Springs

Driver

Side
Gear

Thrust
Washer

Figure 1

LOCK-RIGHT Exploded View

LOCK-RIGHT Installations Covered in This Manual

Removable third member axles. Typical of these are all rear and some front axles in various models of Suzuki 4x4 vehicles. The LOCK-RIGHT is designed to function in 4-pinion differentials only, not in 2-pinion design; to install a LOCK-RIGHT in these differentials a suitable 4-pinion rear differential may be substituted.

Preliminary Steps

The following steps are only a general guide to preliminary operations used for preparing your vehicle for **LOCK-RIGHT** installation. For detailed information, refer to your shop manual. In general, the preliminary steps include:

- a) **Blocking the vehicle**, putting transmission in neutral
- b) **Loosening the wheel lug nuts** (tire removal may be optional; see shop manual)

- c) **Jacking up the axle**; securely resting it on jack stands;
- d) **Removing the tires** (some axles)
- e) **Disconnecting the brake lines** and emergency brake cables (some axles)
- f) **Pulling out one or both axles** a few inches.

Removal and Disassembly

Summary of steps in this section:

- a) Securely block and jack up vehicle
- b) Pull out axle shafts by about six inches
- c) Remove third member from vehicle
- d) Observe ring gear backlash
- e) Mark bearing caps and adjusters
- f) Remove differential case from carrier
- g) Mark bearing races
- h) Remove ring gear
- i) Remove internal parts
- j) Install **LOCK-RIGHT**.

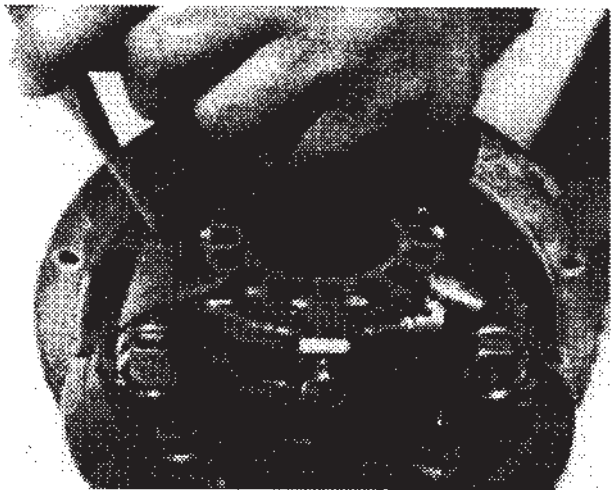

Figure 2
Mark carrier, caps, adjusters at lock hole

Removal of the Differential Case from the Carrier

1. Remove the third member from the vehicle as described in the shop manual. **Follow all safety precautions.**

2. Check to be sure that the third member is in good condition and that nothing is loose, worn or scored. Rock the ring gear back and forth to get a “feel” for the backlash and check to see that it appears to be set up properly. If any out-of-spec conditions exist, be sure to correct them before subsequent re-assembly.

NOTE: The third member itself can be disassembled and re-assembled without changing the ring and pinion settings if *you are careful*. Follow these steps in detail.

3. Mark everything! Don't touch a bolt until you have done so. The easiest tool to use is a **center punch**. We suggest placing the whole assembly upright (the same position as when in the vehicle), looking at the ring gear end.

Mark the carrier and bearing cap on the **ring gear side with one punch mark** and on the **other side with two marks (Figure 2)**. The caps are *not* interchangeable! Also mark each bearing adjuster directly under the lock with this same mark to note its side and rotational position. *This mark is very important to correct re-assembly!*

4. Remove the adjuster locks. (See **Figure 3**). Be sure that each adjuster is marked at the lock with the correct number of punch marks for each side. The adjusters are not interchangeable after they are marked for position! (In general, the adjuster locks themselves are interchangeable.)

5. Remove the bearing caps (Figure 3).

6. Slide (tap) the adjuster up and out and remove the bearing race on the ring gear side first and put a very small grind mark on the outside of the race to mark it. Scraping it on a cement floor also works, or you can use a tag. Be sure that you can identify it for proper re-assembly on the correct side!

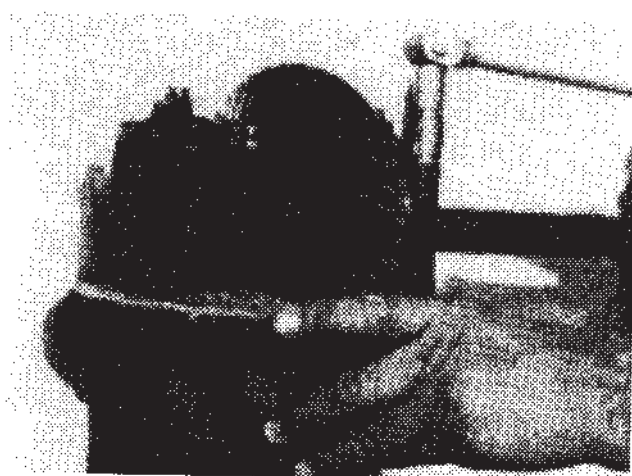

Figure 3
Remove bearing caps and adjuster locks

7. **Remove the differential case** and ring gear assembly from the carrier along with the other adjuster and bearing race.

Disassembly of the Differential Case

1. **Remove the ring gear bolts** and then the ring gear. It may need to be tapped off with a brass mallet. Mark it so that it can be re-installed in the same rotational position as when removed. Also mark the cap and case so that they can be reassembled in the same position.

2. **Remove the case cap.** If it is pressed into position, carefully pry it off. It may either be held on by the ring gear or separately at the opposite end of the case, depending on the vehicle.

3. **Remove the pinion shaft(s),** spider gears, side gears, all washers, and the pinion shaft block.

4. **Mark the side gear in the top of the case** with a tag or put it in a separate location so that it can be identified later. It will be placed in the bottom of the case during assembly.

Inspection of the Parts

NOTE: These steps are important. The **LOCK-RIGHT** utilizes your case, side gear thrust washers, pinion shaft and axle shaft thrust block, (if used), and they must be in excellent condition. The spider gears and washers are not used. If the following inspection shows that anything is bad, buy new parts from your dealer!

1. **Thoroughly wash** the differential case and remaining parts with solvent, then dry them. Be sure to keep the side gears separate, because the side gear in the top of the case will be installed in the bottom of the case during assembly.

2. **Inspect the side gears.** They are very important to the proper operation of your new **LOCK-RIGHT**. The following three figures show various levels of wear on the teeth.

a) **New side gear (Figure 4).** Note that the surface has a slight roughness that remains after the forging operation.

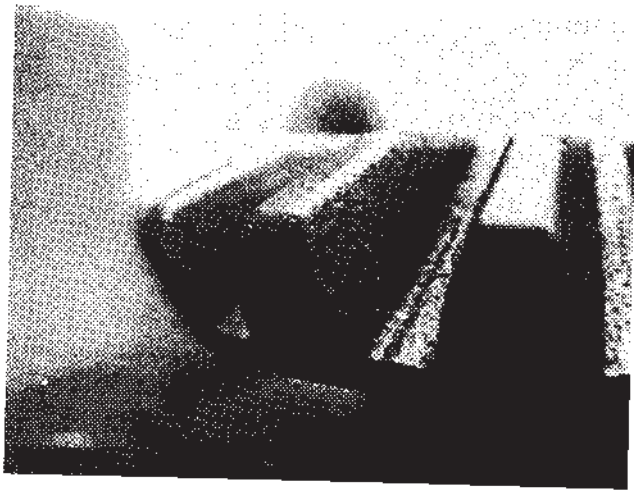

Figure 4
New side gear



Figure 5
Moderately used side gear

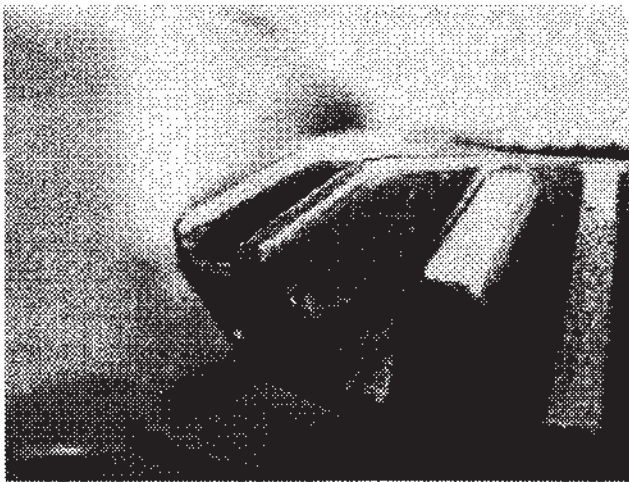

Figure 6
Heavily used side gear

b) Moderately used side gear (Figure 5). Note that some polishing is evident near the top but that the sides of the tooth remain slightly rough.

c) Heavily used side gear (Figure 6). Note the depression worn in the sides of the teeth, tops “rolled” smooth, and highly polished surfaces. Will not function—should be replaced.

3. Inspect the side gear thrust washers. They are important to the correct positioning of the **LOCK-RIGHT** parts. If they are excessively worn or are cracked, obtain new ones.

4. Inspect the pinion shaft block for any damage or excessive looseness. If it is not in excellent condition, obtain a new one.

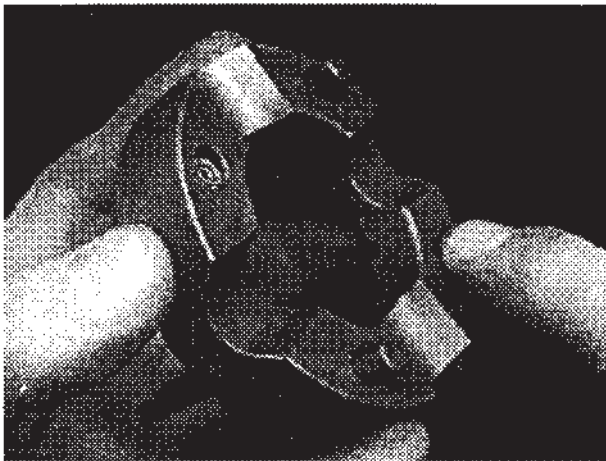

Figure 7
Place grease in holes for "glue"

5. Inspect the case for any chips, cracks or similar damage. Also inspect the bearings. If the case or bearings look bad, replace them. However, if you do, remember that the marked bearing adjuster positions no longer will be correct; the ring and pinion backlash and bearings pre-load will need to be reset with a dial indicator as described in the shop manual.

LOCK-RIGHT Installation

Preparing the Parts for Assembly

Coat the teeth of the drivers and both sides of the thrust washers with medium grease. Also place a little grease in each of the two window holes in each driver (**Figure 7**). The grease will help hold things in place and assist with functioning until the gear oil circulates.

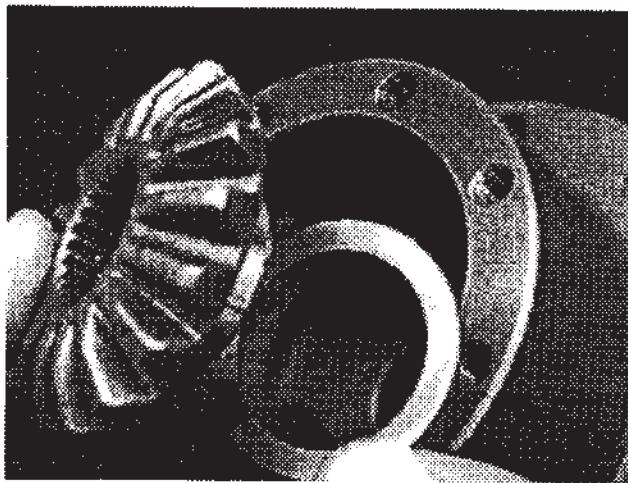

Figure 8
Place washer and former top gear into case

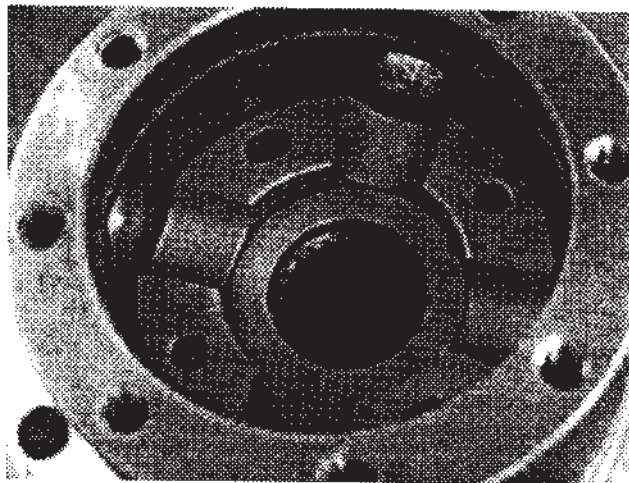

Figure 9
Place drive on gear with spacer in center

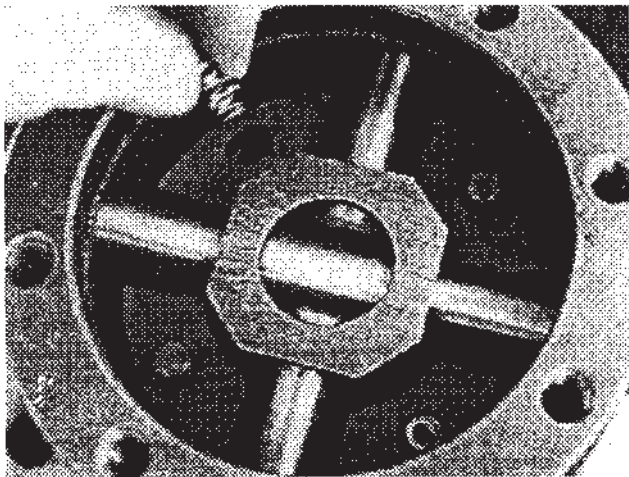

Figure 10
Install pinion shafts, block, pins and springs

Assembly of the LOCK-RIGHT Parts into the Differential Case

Summary of steps in this section:

- a) Install ring gear side coupler and washer
- b) Install ring gear side driver and spacer
- c) Install pinion shaft block and shafts
- d) Install springs and pins
- e) Install pins and springs another driver
- f) Install other driver and spacer
- g) Install other side gear and thrust washer
- h) Install case cap

1. Place a thrust washer into the bottom of the case, smoothest side up, and place the gear that formerly was in the top of the case into the bottom (**Figure 8**).

2. Place a driver onto the side gear in the case, with the teeth meshed, and place one of the spacers in the middle. (**Figure 9**).

3. Install the pinion shaft block and pinion shafts (see **Figure 10**). Note that the pinion shaft block is not a precision part and that the holes may be drilled off-center such that the block is thicker on one side than on the other. The spacer may tend to bind between that side of the block and its corresponding side gear.

To check for this condition, place a spacer in the center of the driver and install the pinion shaft block using the long shaft. Wiggle the block to get a “feel” for the gap between it and the spacer; turn the block over and do the same test for the other side. Install the block with the side down where the gap between the block and spacer is the least. This will assure that when the top space will be adequate.

If the block is too tight and the long shaft will not insert, use a belt sander or grinder to carefully remove about .005-inch from the tight side of the block until the shaft inserts easily. If the removal of any more material is needed, obtain a thinner thrust washer from your dealer or surface grind your present

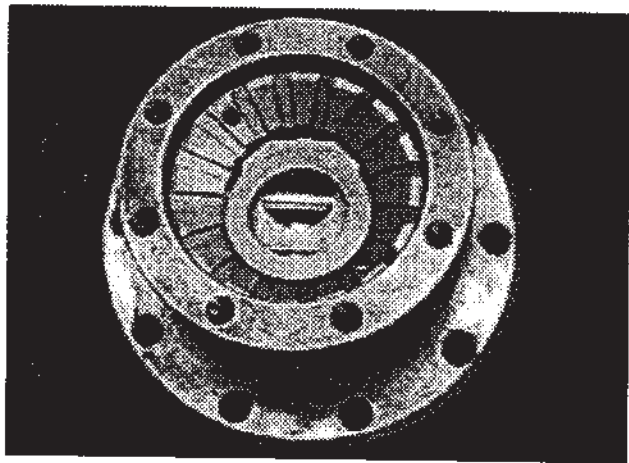

Figure 11
Install top driver and spacer

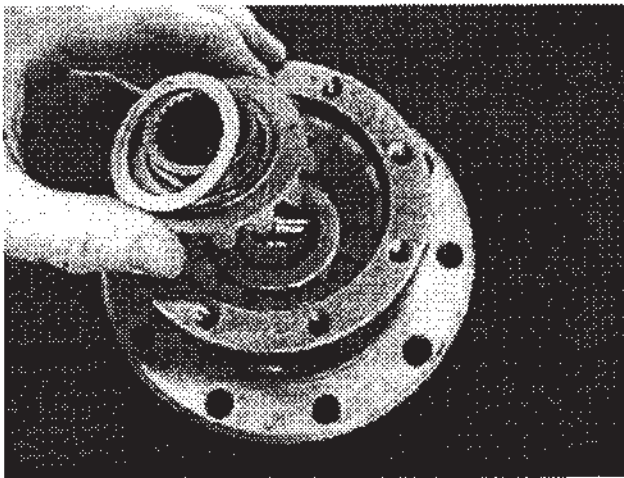

Figure 12
Install former bottom side gear & washer on top

one. Re-install the block with the ground side down and continue with you installation.

4. Insert a small spring into a large spring and place the assembly into one of the large holes in the bottom driver (**Figure 10**). Repeat for the other hole. The grease placed in the holes earlier will help hold things in place.

5. Place a spring assembly into each hole in the other driver. Place a little more grease on top of the springs to help hold them on place (see **Figure 7**).

6. Turn the other driver over and hold it so that the stop pins line up with the springs in the lower driver. Carefully lower it until the pins rest on the springs (see **Figure 11**). Push it up and down to be absolutely sure that everything is in place and that all springs are functioning properly. Proper operation of the parts at this point is very important!

7. Place the other spacer in the middle of the top driver.

8. Place the other side gear (the one that formerly was in the bottom of the case) onto the top driver with the teeth meshed and then place the second thrust washer on it (Figure 12). The smoothest side of the washer is placed next to the gear.

9. Place the case cap onto the case in its marked rotational position. Line up the holes and install the bolts. Torque them to their proper value.

10. Install the ring gear in its proper marked rotational position and then tighten the bolts.

11. Inspect your work. Look for anything that is not correct. Reach in through each end with two fingers into the splines and be sure that the gears and drivers rotate back and forth smoothly, stopping at the pinion shafts.

Third Member Final Assembly

1. Position the carrier vertically, with the drive shaft

flange pointing down. It can be held in a vise or even stood on its nose in a coffee can if a vise is not available.

2. Place the bearing races on the differential case bearings. Be sure to place the marked one on the proper end.

3. Set the differential case (and bearing races) into the carrier. Install it with ring gear pushed all the way into the drive pinion— that is, with *no* backlash, and with the bearing races pushed *all the way* onto the bearings.

4. Check the punch marks on the adjusters and determine which one goes on the side nearest the ring gear. Hold it so that the mark is at its final position (where the lock will be installed, pointing away from the carrier). Push the adjuster against the race and slide it down into the threads in the carrier. They should mesh easily, with no space between the parts.

5. Install the correctly-marked cap. Use the bolts as guides by turning them in two threads or so and then sliding the cap down to meet the case. Be sure that the cap threads fit into those in the adjuster. Do not force anything. The cap should slide down very close to the carrier surface. Tighten the bolts until they are snug (see **Figure 2**).

6. Hold the other adjuster so that the mark is in the same relative position as the other one (with the mark away from the carrier) and slide it down the bearing race into the threads. As it meshes, it should shift outward a little and be positioned slightly away from the race

7. Install the other cap. Again, use the bolts as guides by turning them in two threads or so and then sliding the cap down to meet the case. Turn the bolts until they are barely snug. Be sure that the cap threads fit into those in the adjuster. Do not force anything.

8. Use a spanner wrench or a blunt punch and a hammer to turn the second adjuster (the one away from the ring gear)

one turn inward (clockwise) until the marked hole reaches its final position (in the middle of the cap just below the lock). The last portion of the turn should be difficult because pre-load is being applied to the bearings by spreading the caps apart as the adjuster is being turned in.

9. Insert an axle shaft or bar into one of the axle shaft holes in the differential case to help with holding the assembly or place it in a large vise, and torque the cap bolts to their correct value (see the shop manual).

10. Install the adjuster locks and torque the bolts. Be sure that they are located in the marked holes (as shown in **Figure 2**).

Assembly Inspection

1. Inspect your work. Look for anything that is not correct. Be sure that the drivers rotate back and forth smoothly, stopping at the pinion shaft. Use a light to see that the spacers

(and thrust block, if used) are in place and that the springs are working properly.

When the above installation steps are completed, all the parts should be in exactly the same positions as they were when the installation began. The backlash and pre-load settings should be unchanged from before and no further adjustments will be needed. To be certain, rock the ring gear back and forth to see if the backlash appears to be the same as it was prior to the installation. If not, it will need to be reset with a dial indicator as described in the shop manual. Rotate the ring gear one revolution to be sure that nothing is binding.

Third Member Installation

1. Clean the mating surface of the axle housing and the mounting surface of the differential carrier.

2. Clean the inside of the axle housing to remove all foreign material. This step is very important because metal

chips can interfere with the operation of your new **LOCK-RIGHT**.

3. Remove metal chips from the drain plug if it is magnetic.

4. Install a gasket and/or sealant as appropriate.

5. Lift the third member into the axle housing and shove it into the studs.

6. Install and torque the hardware.

7. Re-install the axle shafts and finish the remaining vehicle re-assembly steps.

Vehicle Final Assembly

Add gear oil. Note that we suggest using medium-to-heavy oils as recommended by the manufacturer, unless the vehicle will be used in very cold weather. Thicker oil, such as 85-140, reduces the “clicking” noise sometimes heard during tight turns and provides adequate lubrication when the assembly becomes hot. Also see the section in the Vehicle Operators Manual regarding temperature.

Your **LOCK-RIGHT** installation should now be complete. As a preliminary test, rotate the tires back and forth (transmission out of gear and driveshaft free). The drivers should randomly unlock and “click” as the tires move. Note that the tires will NOT lock together—this easy-unlocking characteristic is a unique feature of the **LOCK-RIGHT** and is perfectly normal.

Tire Diameters

To help assure a long life for your new **LOCK-RIGHT**, **tire diameters should be as nearly equal as possible**. Contrary to instructions that you may have read elsewhere, **DO NOT** change the inflation pressure to vary the rolling radius of the tire! This practice can be dangerous if one of the tires is under-inflated, producing excess heat, faster tire wear and more difficult vehicle control. The best way to equalize the rotation is to measure the circumference of all the tires, including the spare. Choose ones that are within about 3/8-

inch or less of each other (do not change from side-to-side if they are radials). If one tire is much more worn than the other one, they both should be replaced for safety reasons.

Testing Your Installation

1. **Be sure that the vehicle is safely blocked. Leave the axle assembly on the jack stands**, with both tires free to rotate and the emergency brake off.
2. **Put the transmission and transfer case in gear** to lock the drive shaft.
3. **Rotate the other tires** in the forward direction with your hand until it stop, then hold it. That side of the **LOCK-RIGHT** is now locked.
4. **Rotate one of the tires** in the opposite (reverse) direction. The **LOCK-RIGHT** should “click” as the coupler attached to the axle rotates.

5. Rotate the first tire in the reverse direction and hold it; repeat step 3, rotating the other tire in the forward direction.

6. Repeat steps 2 - 4, rotating and holding the second tire to lock the second side.

Driving Your Vehicle

If the foregoing measurements and tests have been successfully completed, apply the emergency brake and remove the vehicle from the jack stands. Your vehicle should now be ready to drive.

*Carefully read and understand the driving information contained in the **LOCK-RIGHT** Vehicle Owner's Manual! Safe and effective use of your new **LOCK-RIGHT**-equipped vehicle depends on knowledgeable operation, and this can only be done by understanding its characteristics before you start. Be careful, and have fun!*

Warranty Information

The Warranty is contained in the Vehicle Owner's Manual that is supplied with your new **LOCK-RIGHT**. Consult this manual for complete warranty information.

Important

If your differential case or thrust washers are excessively worn, your new Lock-Right Locker may not be able to operate as it was designed. Therefore, two easy measurements must be made before final assembly to assure that your new locker will function properly. To make these measurements, proceed as follows:

1. Remove the existing spider gears, side gears and thrust washers from the differential case, and thoroughly clean it.
2. Install the Lock-Right couplers with the existing thrust washers in each end of the case.
3. Place the spacers onto the centers of the couplers (wide side toward the axle splines if not symmetrical), and hold them there.
4. Install the pinion shaft; carefully guide it past the spacers as it is being inserted through the holes in the case.
5. Measure the gap between each spacer and the pinion shaft with a feeler gauge. This gap should be between .005-inch and .020-inch, with not more than a .008-inch difference between the two.

If your numbers are within the limits specified, remove the parts and begin your installation. If your numbers are not within these limits, check the thrust washers and the differential case. If they are excessively worn or are damaged, they may need to be replaced before installing your new Lock-Right Locker.

If you have any questions, call RICHMOND GEAR TechLine at 1-864-843-9275 for further assistance.

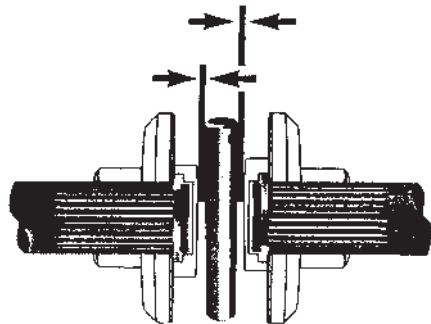



IMPORTANT INFORMATION

Please Read Carefully



The following  and  information is supplied to you for your protection and to provide you with many years of trouble free and safe operation of your Richmond Gear product.

Read **ALL** instructions prior to operating transmission and/or ring and pinion. Injury to personnel, transmission or ring and pinion failure may be caused by improper installation, maintenance or operation.

 **DANGER** • **It is dangerous to get under a jacked-up vehicle.** The vehicle could slip off the jack and fall on you. You could be crushed. Never place any part of your body under a vehicle that is on a jack. Never start or run the engine while the vehicle is on a jack. **If you need to get under a raised vehicle, take it to a service center where it can be raised on a lift.**

 **WARNING** • Hot oil can cause severe burns. Use extreme care when removing lubrication plugs and when working close to a unit that has been in operation.

- Check lube level between scheduled lube changes to insure that proper lube level is maintained. Inspect vent plug to insure it is clean and operating. Inspect the tightness of mounting bolts, misalignment of connecting shafts, lube leakage, excessive heating, or any unusual noise or vibration.
- Serious personal injury may occur as a result of improperly performed maintenance, adjustments or repairs.
- Do not attempt any of the maintenance, checks or repairs described on the following pages if you are not fully familiar with these or other procedures with respect to the transmission, or are uncertain as to how to proceed. Have the necessary work done by a properly equipped and qualified workshop.
- Always be extremely careful when working on the transmission. Always follow commonly accepted safety practices and general common sense. Never risk personal injury.

(continued on next page)



- Do not operate the transmission or ring and pinion without proper lube and correct amount.
- For safe operation and to maintain the unit warranty, when changing a factory installed fastener for any reason, it becomes the responsibility of the person making the change to properly account for fastener grade, thread engagement, load, tightening torque and the means of torque retention.
- Mounting bolts should be periodically checked to ensure that the unit is firmly anchored for proper operation.
- These instructions are not intended to cover all details or variations in equipment, nor provide for every possible contingency to be met in connection with selection, installation, operation, and maintenance. Should further information be desired or should particular problems arise which are not covered sufficiently for the Buyer's purpose, the matter should be referred to Richmond Gear.

In the event of the resale of any of the goods, in whatever form, Resellers/Buyers will include the following language in a conspicuous place and in a conspicuous manner in a written agreement covering such sale:

The manufacturer makes no warranties or representations, express or implied, by operation of law or otherwise, as to the merchantability or fitness for a particular purpose of the goods sold hereunder. Buyer acknowledges that it alone has determined that the goods purchased hereunder will suitably meet the requirements of their intended use. In no event will the manufacturer be liable for consequential, incidental or other damages. Even if the repair or replacement remedy shall be deemed to have failed of its essential purpose under Section 2-719 of the Uniform Commercial Code, the manufacturer shall have no liability to Buyer for consequential damages.

Resellers/Buyers agree to also include this entire document including the danger, warnings and cautions above in a conspicuous place and in a conspicuous manner in writing to instruct users on the safe usage of the product.

This information should be read together with all other printed information supplied by Richmond Gear.



HI-PERFORMANCE PRODUCTS...



RING & PINIONS



LIGHTENED GEARS



INSTALLATION KITS



TRANSMISSIONS



TRANSMISSION FLUID



QUICK CHANGE REAR ENDS



REAR END LUBE



INSTRUCTIONAL VIDEOS



SPOOLS & MINI-SPOOLS



CORD REELS



SHOPLIGHTS



EXTREME TRACTION SYSTEMS



P.O. Box 238, 1208 Old Norris Road, Liberty, S.C. 29657

Phone (864) 843-9231 • Tech Support (864)843-9275 • Fax (864)843-1276 • www.richmondgear.com